

40+ dB  
FD-30





# Tri-Sound DB+ Series 3

## ACOUSTIC/FIRE DOOR CORES

### PERFORMANCE TABLES



#### Acoustic Performance Summary —Single Leaves

	Acoustic Seal Set	Threshold required	Intumescent seal(s)			Glass Type	dB (Rw) Rating	Fire Rating
			Jamb	Head	Meeting Stile			
<b>Single Leaf - Flush</b>								
SLSS Flush	A	none	n/a	n/a	n/a	n/a	39dB	NFR
SLSS Flush	B	none	n/a	n/a	n/a	n/a	41dB	NFR
SLSS Flush	D	none	1no LOR DS1504	2no LOR DS1504	n/a	n/a	39dB	NFR
SLSS Flush	E	LOR IS4015	1no LOR DS1504	2no LOR DS1504	n/a	n/a	43dB	NFR
SLSS Flush	G	None	1no ST1504	2no ST1504	n/a	n/a	40dB	FD30S
SLSS Flush	A	none	1no 15x4 pyroplex <sup>1</sup>	2no 15x4 pyroplex <sup>1</sup>	n/a	n/a	39dB	FD30S
SLSS Flush	B	none	1no 15x4 pyroplex <sup>1</sup>	2no 15x4 pyroplex <sup>1</sup>	n/a	n/a	41dB	FD30S
SLSS Flush	D	none	1no LOR DS1504	2no LOR DS1504	n/a	n/a	39dB	FD30S
SLSS Flush	E	LOR IS4015	1no LOR DS1504	2no LOR DS1504	n/a	n/a	43dB	FD30S
SLSS Flush	G	None	1no ST1504	2no ST1504	n/a	n/a	40dB	FD30S
<b>Single Leaf - Glazed</b>								
SLSS Glazed	A	none	n/a	n/a	n/a	6.4mm Clear Lam	38dB	NFR
SLSS Glazed	A	none	n/a	n/a	n/a	15mm pyrostop	41dB	NFR
SLSS Glazed	B	none	n/a	n/a	n/a	6.4mm Clear Lam	40dB	NFR
SLSS Glazed	B	none	n/a	n/a	n/a	15mm pyrostop	43dB	NFR
SLSS Glazed	E	LOR IS4015	1no LOR DS1504	2no LOR DS1504	n/a	15mm pyrostop	41dB	NFR
SLSS Glazed	E	LOR IS4015	1no LOR DS1504	2no LOR DS1504	n/a	23mm pyrostop	41dB	NFR
SLSS Flush	G	None	1no ST1504	2no ST1504	n/a	15mm pyrostop	40dB	NFR
SLSS Glazed	A	none	1no 15x4 pyroplex <sup>1</sup>	2no 15x4 pyroplex <sup>1</sup>	n/a	15mm pyrostop	41dB	FD30S
SLSS Glazed	B	none	1no 15x4 pyroplex <sup>1</sup>	2no 15x4 pyroplex <sup>1</sup>	n/a	15mm pyrostop	43dB	FD30S
SLSS Glazed	E	LOR IS4015	1no LOR DS1504	2no LOR DS1504	n/a	15mm pyrostop	41dB	FD30S
SLSS Glazed	E	LOR IS4015	1no LOR DS1504	2no LOR DS1504	n/a	23mm pyrostop	41dB	FD30S
SLSS Flush	G	None	1no ST1504	2no ST1504	n/a	15mm pyrostop	40dB	FD30S

Note 1: Pyroplex intumescent seals (as tested) or any PVC-encased graphite based intumescent seal or Lorient 617



# S3K - FD30

Tri-Sound DB+ Series 3  
ACOUSTIC/FIRE DOOR CORES  
PERFORMANCE TABLES



Acoustic Performance Summary —Double Leaves

	Acoustic Seal Set	Threshold required	Intumescent seal(s)			Glass Type	dB (Rw) Rating	Fire Rating
			Jambs	Head	Meeting Stile			
<b>Double Leaf - Flush</b>								
DLSS Flush	C	NOR650	n/a	n/a	n/a	n/a	38dB	NFR
DLSS Flush	C	NOR650	1no 15x4 pyroplex <sup>1</sup>	2no 15x4 pyroplex <sup>1</sup>	2no 10x4 pyroplex <sup>1</sup>	n/a	38dB	FD30S
DLSS Flush	F	LAS 5410	1no LP 1504 DS	2no LP1504 DS	2no LP1004 DS	n/a	40dB	NFR
DLSS Flush	F	LAS 5410	1no LP 1504 DS	2no LP1504 DS	2no LP1004 DS	n/a	40dB	FD30S
<b>Double Leaf - Glazed</b>								
DLSS Glazed	C	NOR650	n/a	n/a	n/a	6.4mm Clear Lam	37dB	NFR
DLSS Glazed	C	NOR650	n/a	n/a	n/a	15mm pyrostop	40dB	NFR
DLSS Glazed	C	NOR650	1no 15x4 pyroplex <sup>1</sup>	2no 15x4 pyroplex <sup>1</sup>	2no 10x4 pyroplex <sup>1</sup>	15mm pyrostop	40dB	FD30S

Note 1: Pyroplex intumescent seals (as tested) or any PVC-encased graphite based intumescent seal or Lorient 617



**S3K - FD30**

# Tri-Sound DB+ Series 3

## ACOUSTIC/FIRE DOOR CORES

### PERFORMANCE TABLES



#### Assessed Fire Performance Parameters

Single Acting Single Leaf  
with or without Transomed Overpanel

UNLATCHED FD30 in Red Solid

LATCHED FD30 in Blue Dashed

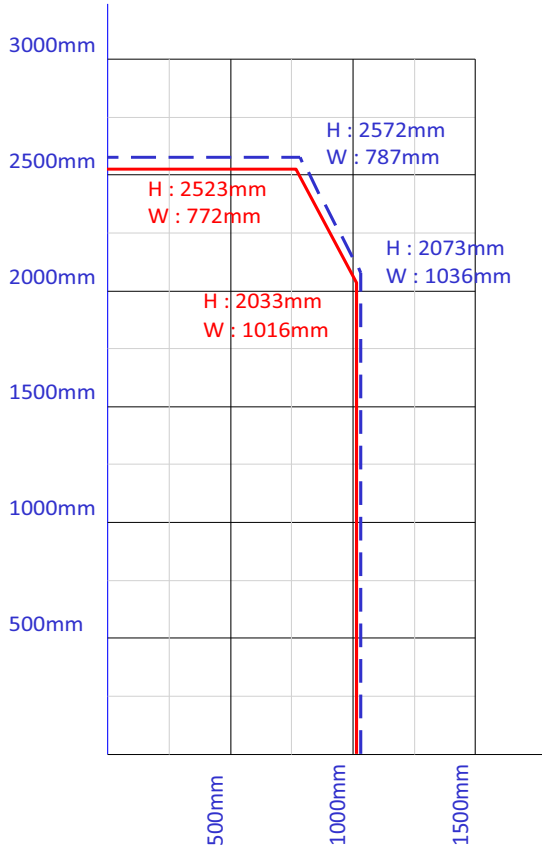

Single Acting Double Leaf  
with or without Transomed Overpanel

UNLATCHED FD30 in Red Solid

LATCHED FD30 in Blue Dashed

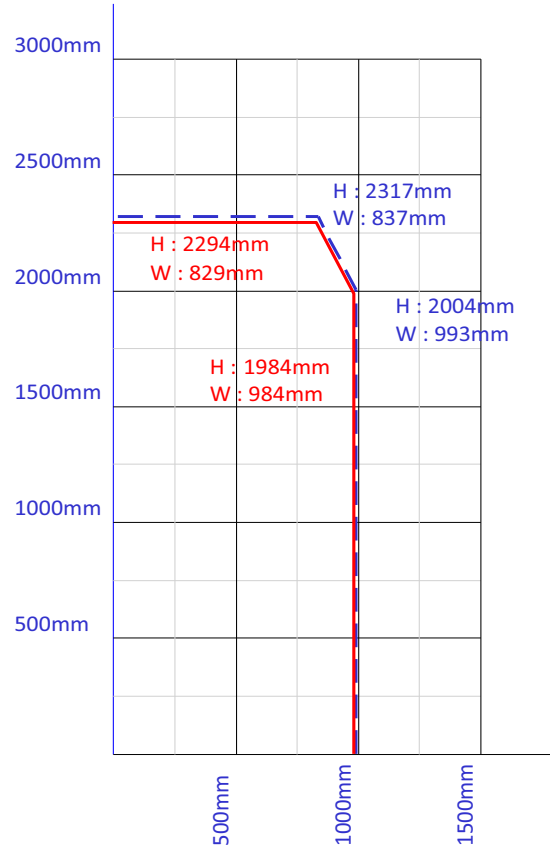

Assessed Fire Performance Parameters from IFC Field Of Application PAR\_10651\_01  
Construction and configuration must be as per the detail in this report.

#### Acoustic Seal Sets

Seal Set	Head	Jambs	Base	M/S
A	NOR710	NOR710	NOR810	
B	NOR710 & NOR720	NOR710 & NOR720	NOR810	
C	NOR710 & NOR720	NOR710 & NOR720	NOR810	2 x NOR720
D	LOR DS & IS1010	LOR DS & IS1010	IS8040	
E	LOR DS & IS1010	LOR DS & IS1010	2xIS1511	
F	LOR DS & IS1212	LOR DS & IS1212	LAS 8001SI	LOR DS
G	ST 1009	ST 1009	ST 422	



# S3K - FD30

# Tri-Sound DB+ Series 3

## ACOUSTIC/FIRE DOOR CORES

### INTRODUCTION



The Tri-Sound DB+ acoustic door core is supplied as 3-ply core material with cork outer layers sized at a nominal 2000 x 800mm plan size. It requires making up into a door blank by adding timber perimeter and chipboard or MDF substrates. Once complete, the door blank can then be trimmed, lipped and faced to make a door.

Tri-Sound DB+ has been tested rigorously for both fire and acoustic performance, achieving 30 minute fire rating, in accordance with BS476 part 22, to well over standard leaf sizes and up to Rw43dB sound attenuation when tested to BS EN ISO 717-1:1997. Cold Smoke seal requirement to BS476 part 31 comes as standard with every seal combination.

#### Contents

1. Manufacturing the Blank from the Core material	
a. Deciding on Blank Size	Page 2
b. Materials required	Page 2
c. Sizing the Core Material	Page 3
d. Making up the Blank	Page 4
2. Turning the Blank into a door	
a. Trimming	Page 6
b. Lipping	Page 6
c. Facing	Page 7
d. Glazing	Page 7
3. Frames & Seal configurations	
a. Frame Details	Page 8
b. Single Leaf Seal Set A	Page 8
c. Single Leaf Seal Set B	Page 9
d. Single Leaf Seal Set D	Page 10
e. Single Leaf Seal Set E	Page 11
f. Double Leaf Seal Set C	Page 12

# Tri-Sound DB+ Series 3

## ACOUSTIC/FIRE DOOR CORES

### SECTION 1– MANUFACTURING THE BLANK



#### Deciding on a Blank Size

##### Lipping size

The blank size to be manufactured can only be determined once the lipping size and configuration has been decided upon. A minimum 6mm Lipping must be applied to the hanging stiles and an optional lipping can be applied to the top and bottom rails. The following table gives the lipping options in full.

Location on Leaf	Lip Material	Lipping Requirement	Square Lip Min Thickness <sup>1</sup>	Square Lip Max thickness	Rebated Lip Min Thickness <sup>1</sup>	Rebated Lip Max Thickness
Hanging Stile	Hardwood min 630Kg/m <sup>3</sup>	Required	6mm	15mm	22mm	22mm
Meeting/Lock Stile	Hardwood min 630Kg/m <sup>3</sup>	Required	6mm	15mm	22mm	22mm
Top Rail	Hardwood min 630Kg/m <sup>3</sup>	Optional	6mm	15mm	22mm	22mm
Bottom Rail	Hardwood min 630Kg/m <sup>3</sup>	Optional	6mm	15mm	22mm	22mm

Note 1 : minimum thickness of lipping where fitted if requirement is optional

##### Trim Amount

The blank must be trimmed to square up the four edges before lipping and generally we would recommend trimming by 6mm from all four edges. It may be possible to trim as little as 3mm and still retain a straight trimmed edge, depending mainly on the true nature of the perimeter timber and the accuracy of the pressing process. It is also possible to trim a greater amount up to 15mm from each edge although care must be taken to avoid the positions of the steel staples in the perimeter timber.

##### Calculating Blank Size

The following formulas give the blank size prior to trimming:

$$\text{Blank Width} = \text{Leaf Width} + \text{Trim Stile1} - \text{Lip thickness 1} + \text{Trim Stile 2} - \text{Lip Thickness2}$$

$$\text{Blank Height} = \text{Leaf Height} + \text{Trim Top} - \text{Top Rail Lip thickness} + \text{Trim Bottom} - \text{Bottom Rail Lip Thickness}$$

##### Example

For a Leaf requirement of 2040x926mm, lipped 2 vertical edges only with 10mm lippings and the recommended trim amount of 6mm from each edge:

$$\text{Blank Width} = 926 - 10 - 10 + 6 + 6 = 918\text{mm}$$

$$\text{Blank Height} = 2040 - 0 - 0 + 6 + 6 = 2052\text{mm}$$

#### Materials List for Blank Manufacture

Tri-Sound DB+ 45mm thick 3-Ply acoustic core with Cork outer layers (nom 2000x800mm)

Sitka Spruce (min density 450kg/m<sup>3</sup> at 12% mc) 46x38mm section perimeter timber

46x2mm Therm-A-Line Intumescent material

4mm Chipboard/MDF sheets for substrates

Min 20x12mm steel staples

Apollo A7561 adhesive

# Tri-Sound DB+ Series 3

## ACOUSTIC/FIRE DOOR CORES

### SECTION 1- MANUFACTURING THE BLANK



#### Sizing the Core Material

Core Height: Blank Height – 152mm – 4mm

Core Width: Blank Width – 152mm – 4mm

Where Fire performance is required the following four conditions must also be adhered to:

- i. the core must only be used in the “portrait” orientation
- ii. When cutting the core to width it is imperative to ensure that the required amount is only trimmed from one edge of the core. If the non-cut edge requires squaring-up this can be achieved by trimming a maximum of 6mm before the remainder is trimmed from the opposite edge.
- iii. The core is normally supplied at 2000x800mm dimensions. If a higher and/or wider core size is required then more than one piece of core can be used provided not more than one vertical joint and one horizontal joint are introduced. Horizontal joints should be kept as close to the bottom of the door as possible. Where both horizontal and vertical joints are present, the horizontal joint should be staggered by a minimum of 100mm to avoid a “+” shaped joint. All joints should be packed with 2mm Therm-A-Line. See detail below for allowable layouts:

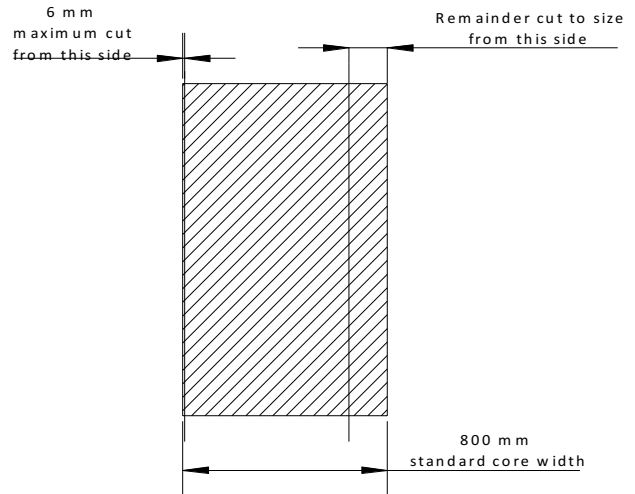

Core Width > 800mm

Core Height > 2000mm

Core Height > 2000mm & Core Width > 800mm

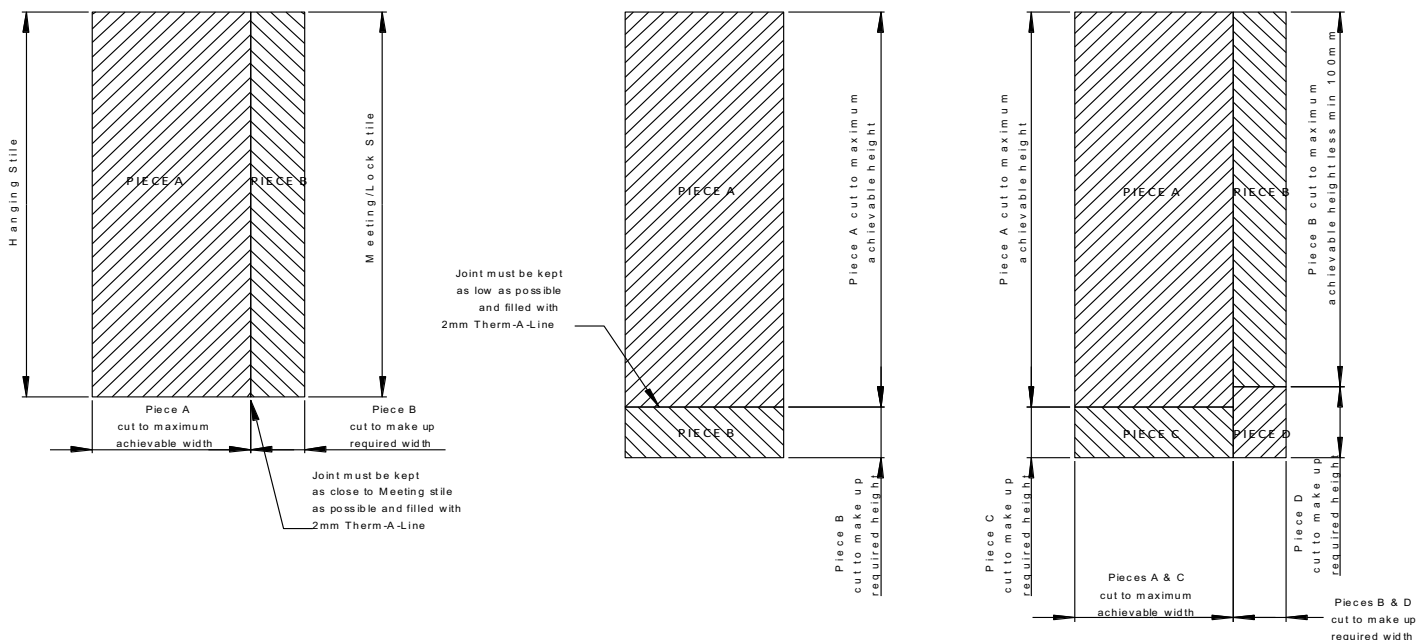

- iv. In any event the overall leaf sizes should be limited to the permissible envelope provided with the fire performance evidence.



# Tri-Sound DB+ Series 3

## ACOUSTIC/FIRE DOOR CORES

### SECTION 1- MANUFACTURING THE BLANK



#### Making Up The Blank

##### Cut Perimeter Timber:

Outer stiles: Blank Height

Inner stiles: Blank Height – 152mm

All rails: Blank Width – 76mm

##### Cut substrate (2 faces):

Height: Blank Height + 4mm

Width: Blank Width + 4mm

#### Blank General Arrangement

The diagram to the right shows the general arrangement of the made-up blank. Note that the top area of the blank is different to the bottom.

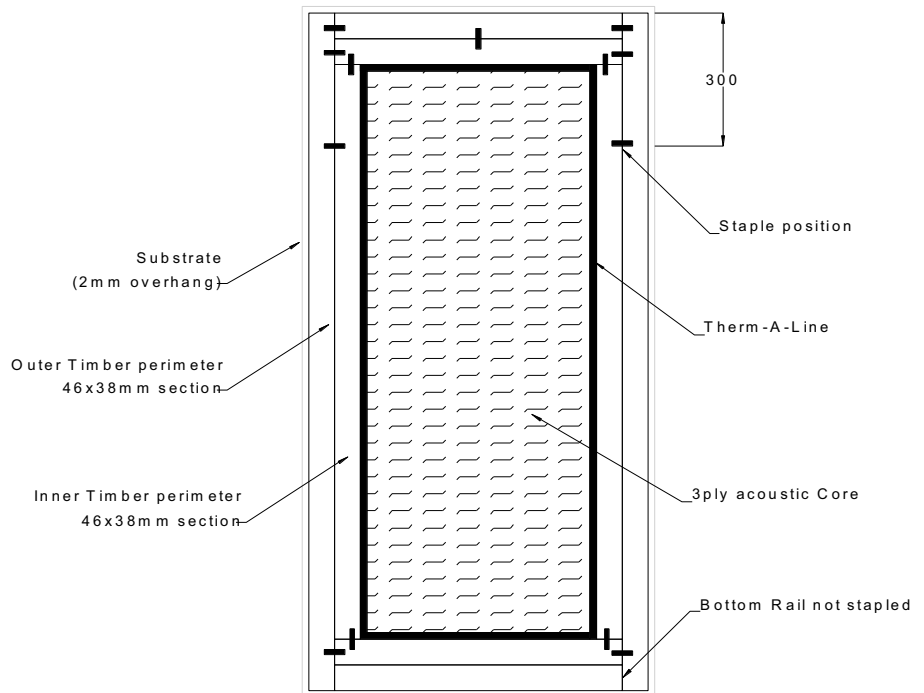

#### Assembly Method

Assemble Perimeter using steel staples from both faces, in locations shown above, ensuring tight fit of timber at joints and where butted up. Gaps of > 0.5mm are unacceptable. Note that the bottom rail is not stapled.

Coat one substrate with Apollo A7561 adhesive ( $140\text{Kg/m}^2$ ) and over mist with water (5% of the adhesive weight used). Avoid excessive water. Place (adhesive side up) on pressing platform

Place perimeter onto substrate with 2mm overlap all round

Place the bottom rail ensuring tight fit

Attach Therm-A-Line to internal edge of perimeter

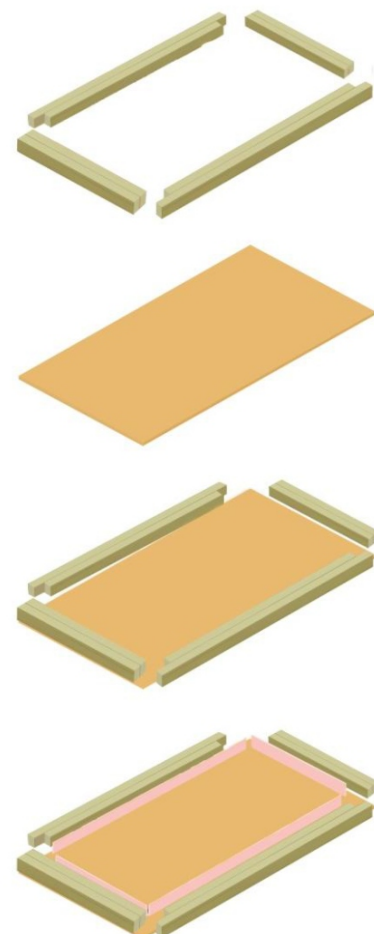

(Method continues on next page)

# Tri-Sound DB+ Series 3

## ACOUSTIC/FIRE DOOR CORES

### SECTION 1– MANUFACTURING THE BLANK



Place cut-to-size core material into the perimeter

Where more than one piece of core is used ensure that additional Therm-A-Line is paced between each core piece

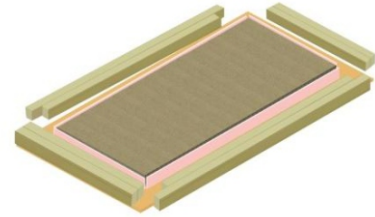

Coat second substrate with Apollo A7561 adhesive, mist with water and place on top of core/perimeter

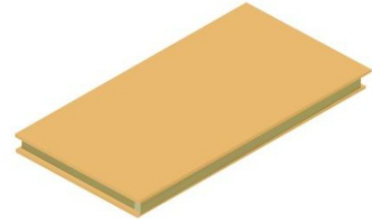

Use a marker pen to mark "Top" on the top perimeter frame.

Press in a hot press until adhesive is cured to the handling stage. Suggested time in a hot press would normally be around 20-30 minutes but the time required will vary due to press temperature and other conditions. It is possible to use a cold press although pressing time to reach the handling stage will be significantly increased, e.g. in a 21°C environment the handling stage would normally be reached in around 75 minutes, although again this will vary due to conditions. For more information see the adhesive manufacturers Technical Data Sheet

Once the handling stage of curing is reached the blank can be removed from the press but handling should be kept to a minimum until full cure has been achieved. Time required to achieve full cure varies with temperature and other conditions but as a guide a blank stored in normal conditions should achieve full cure after around 24 hours.

Once full cure has been reached the blank can be trimmed, lipped and veneered according to requirements. See Section 2 of this Technical Manual for more information regarding use of the blank.

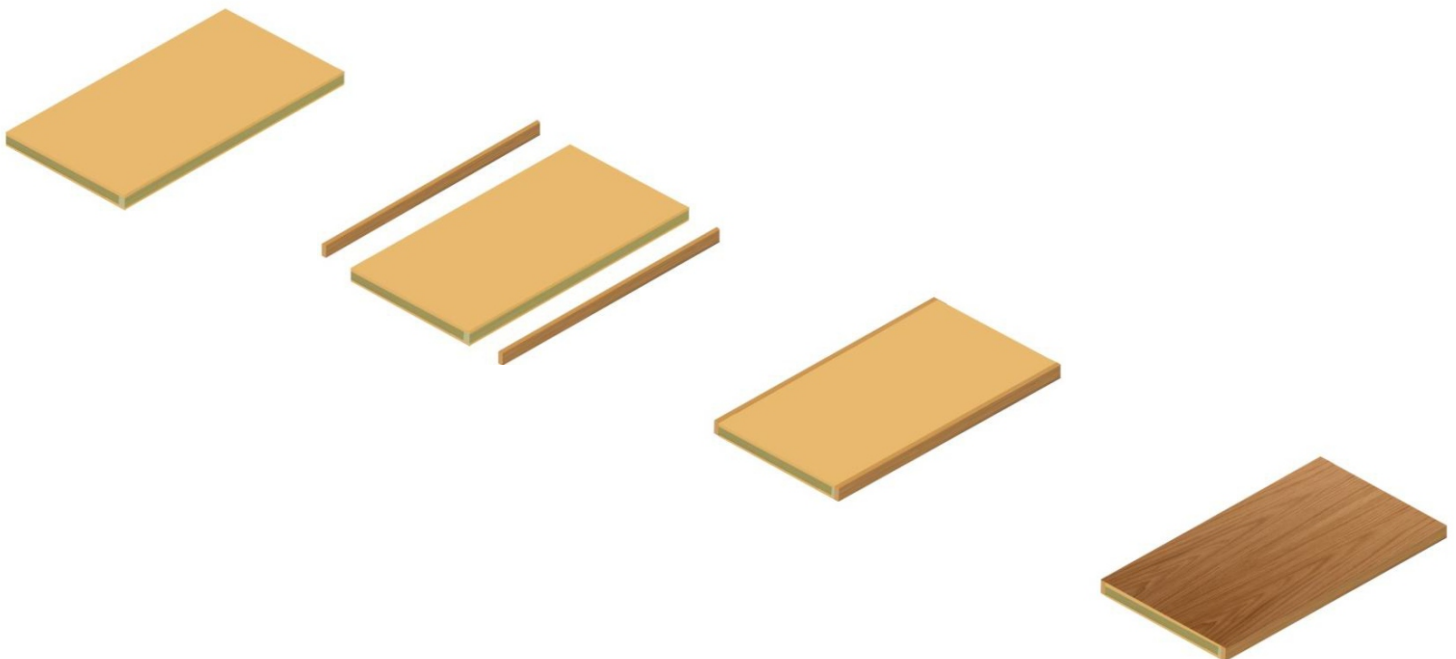

# Tri-Sound DB+ Series 3

## ACOUSTIC/FIRE DOOR CORES

### SECTION 2– FROM BLANK TO DOOR LEAF



#### Trimming

Tri-Sound DB+ blanks manufactured in accordance with Section 1 of this Technical Manual will still be in an un-trimmed state. They must be trimmed on all four edges by a recommended 6mm and in any event by a minimum of 3mm up to a maximum of 15mm prior to lipping. This provides a straight, true edge for lipping bonding on stiles and rails or (for rails only) to use as the finished leaf edge. The trim amount does not have to be the same for each edge so long as no more than 15mm is trimmed from one edge.

The leaf/Blank size relationship was discussed in Section 1 but slight alterations to the leaf size can still be made at this point by varying the trim amount and the lipping thickness.

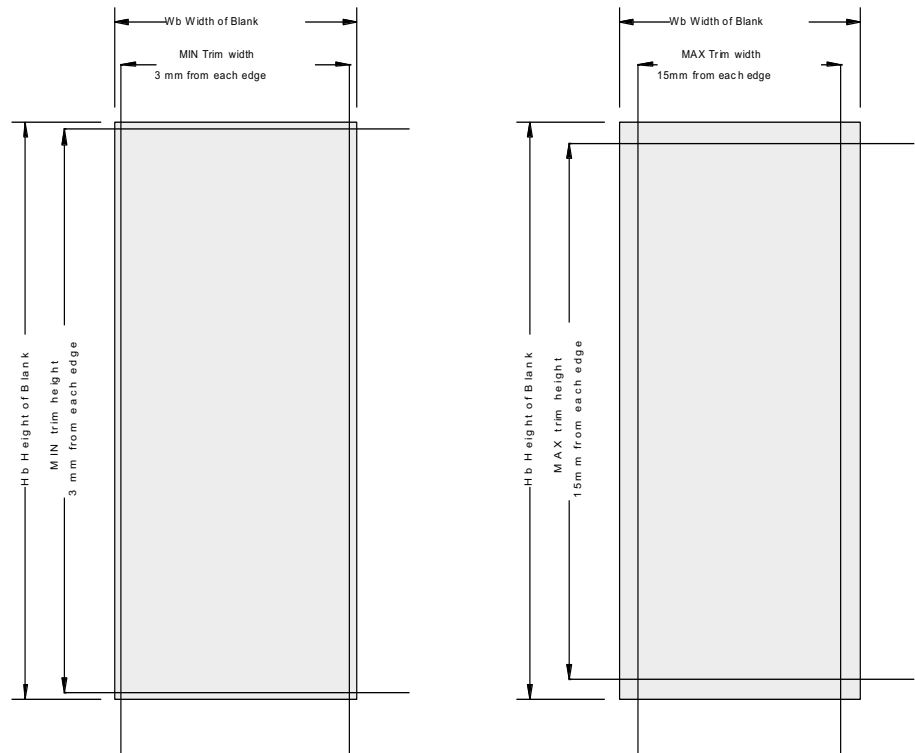

To calculate the finished leaf size:

$$\text{Finished Leaf Width} = \text{Blank Width} - \text{Trim Stile1} + \text{Lip Th1} - \text{Trim Stile2} + \text{Lip Th2}$$

$$\text{Finished Leaf Height} = \text{Blank Height} - \text{Trim Top} + \text{Top Lip Th} - \text{Trim Bottom} + \text{Bottom Lip Th}$$

#### Lipping

##### Vertical Stiles

A minimum 6mm lipping manufactured from hardwood (min density 630Kg/m<sup>3</sup>) must be applied to the stiles. Lippings must be attached using Urea Formaldehyde, Polyurethane or PVA-C adhesives.

Square or rebated meeting stiles can be applied to double doors with rebated meeting stiles formed from 22mm lippings as shown. We recommend that rebated meeting stile lippings are not concealed by any veneer or painting foil

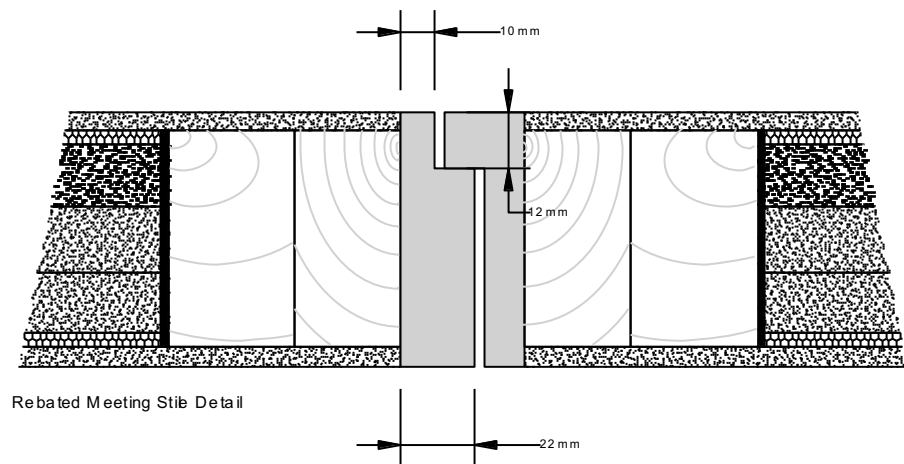

##### Top & Bottom Rails

We recommend lipping the top & bottom rails with a minimum 6mm hardwood lip (min density 630Kg/m<sup>3</sup>) but if required the trimmed timber perimeter can be left as the finished leaf edge. If a lipping is applied, it must be attached using Urea Formaldehyde, Polyurethane or PVA-C adhesives.

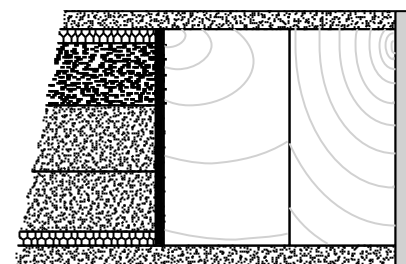

6mm Square Lipping Detail

# Tri-Sound DB+ Series 3

## ACOUSTIC/FIRE DOOR CORES

### SECTION 2- FROM BLANK TO DOOR LEAF



#### Facings

Tri-Sound DB+ is very flexible with regard to the appearance of the finished door leaf. Decorative facings up to 2mm thick can be applied to the Tri-Sound DB+ chipboard substrate including wood veneers, plastic based laminates, pvc or paint. We recommend the use of paint-grade veneers or painting foils where a painted finish is required.

#### Glass Openings

Glass Openings of up to 25% of the leaf size can be formed by cutting out through the substrate and core. Glazing bead detail must be as shown, with the bolection sandwiching the blank.

Margins to top and vertical edges must be no less than 150mm.

Multiple glass openings can be created provided that the total glass opening area is no more than 25% of the leaf size and the margins between glass openings are no less than 150mm.

Where Fire performance is also required the maximum total glazing area must not in any event exceed 0.422m<sup>2</sup> or 25% of the leaf area (whichever is the lesser).

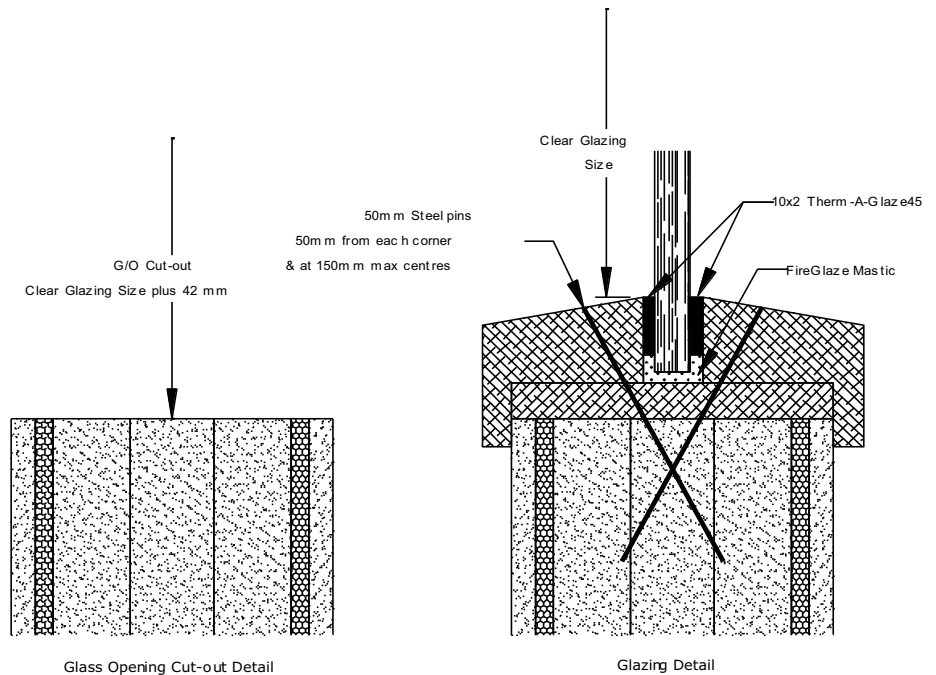

#### Glazing

The following Glass types are to be used with reference to the Performance Tables at the end of this manual:

- 6.4mm clear laminated Glass
- 15mm Pyrostop (Pilkington Glass Ltd)
- 23mm Pyrostop (Pilkington Glass Ltd)

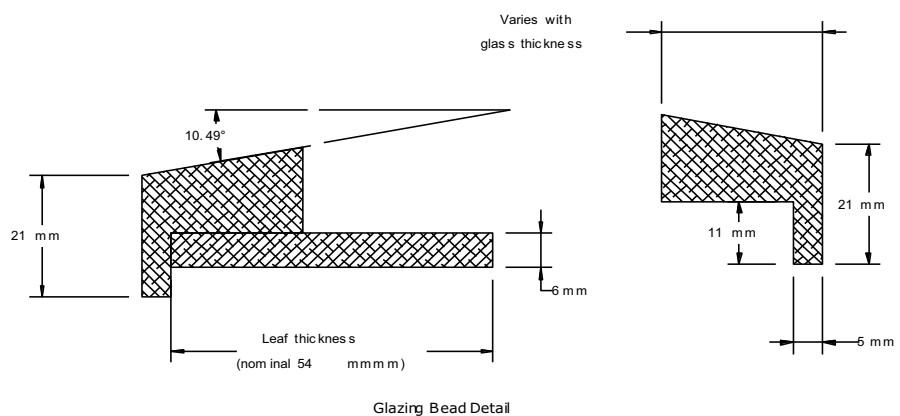

#### Glazing Beads

Bead detail is to be as shown above with beads and liner to be manufactured from hardwood with minimum density 630 Kg/m<sup>3</sup>.

# Tri-Sound DB+ Series 3

## ACOUSTIC/FIRE DOOR CORES

### SECTION 3- FRAME & SEAL CONFIGURATIONS



#### Frames

Door frame and stop minimum dimensions are as shown below with frame material being Softwood (min density 450Kg/m<sup>3</sup>), MDF or Hardwood (min density 630Kg/m<sup>3</sup>). All door frame timber for fire rated doorsets must meet or exceed Class J30 as specified in BS EN 942:1996.

#### Single Leaf – Seal Set A

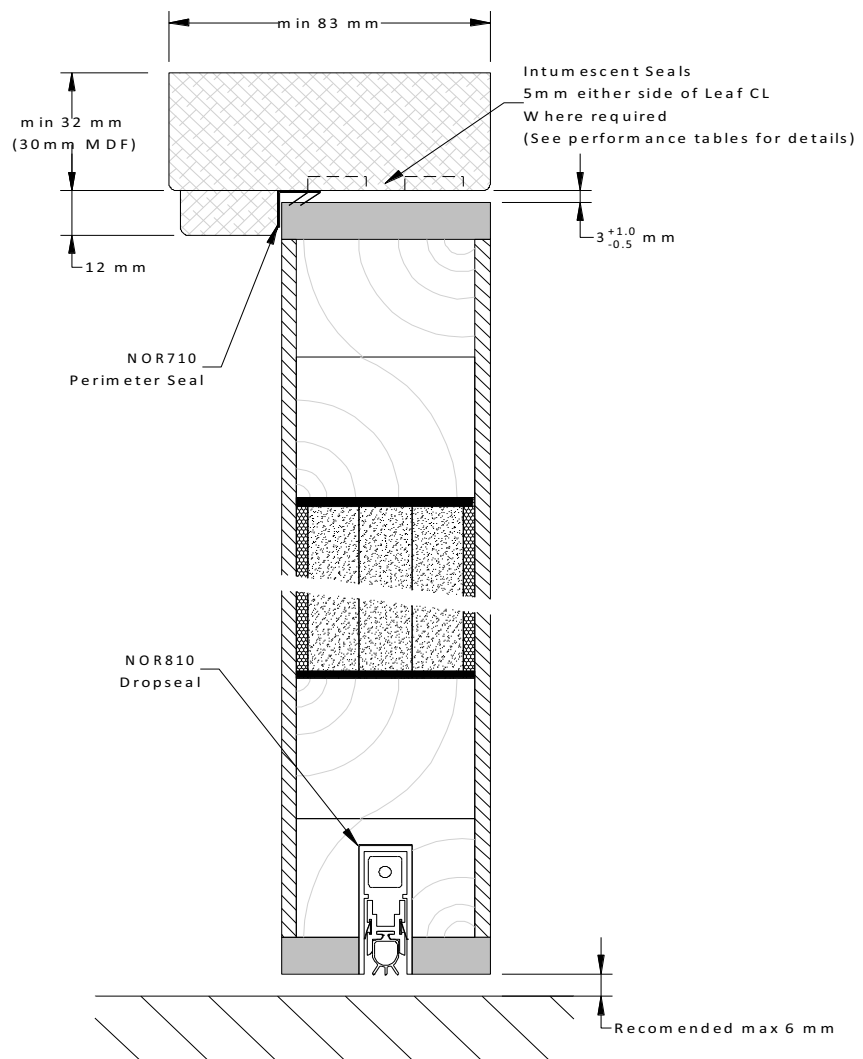
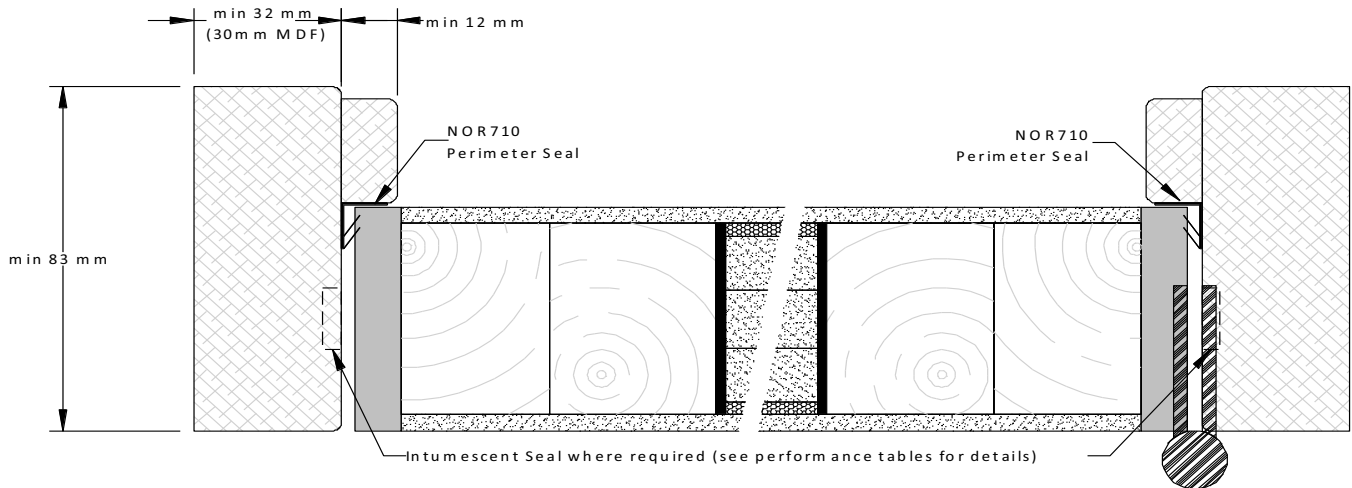

Tri-Sound DB+ Series 3  
 ACOUSTIC/FIRE DOOR CORES  
 SECTION 3- FRAME & SEAL CONFIGURATIONS



Single Leaf – Seal Set B

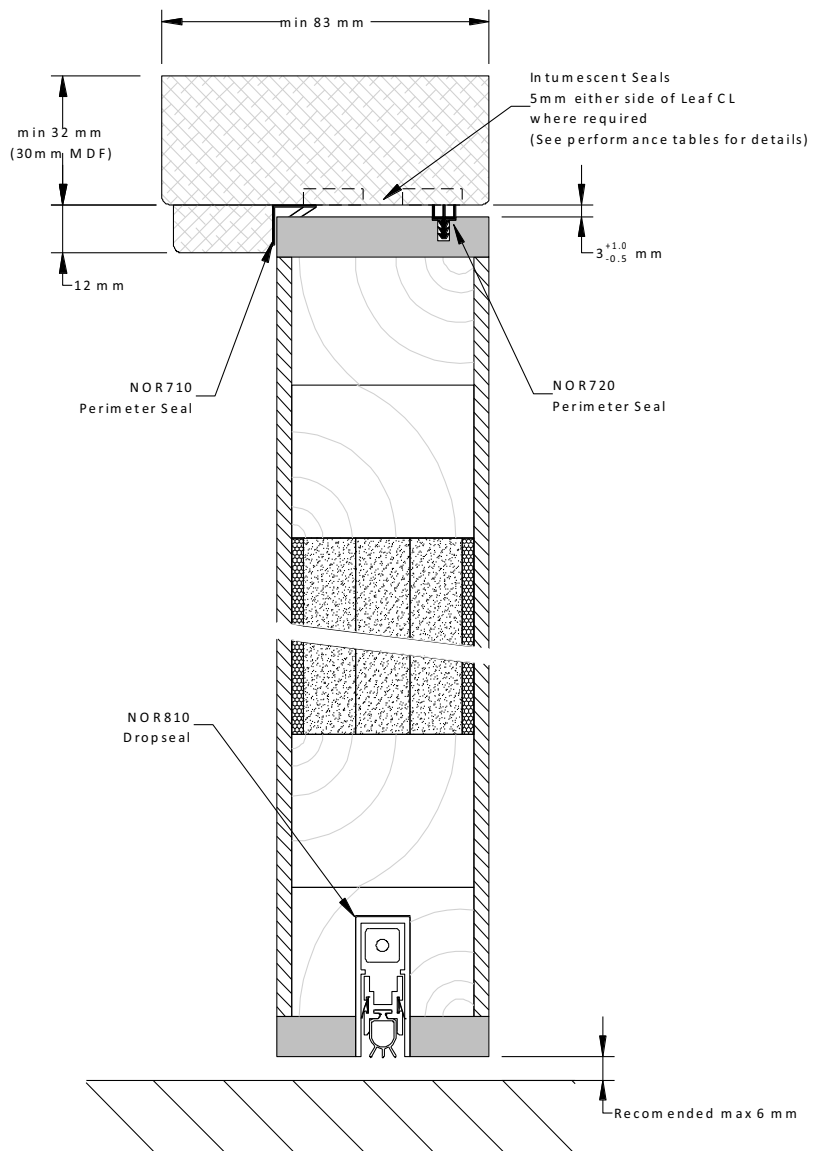
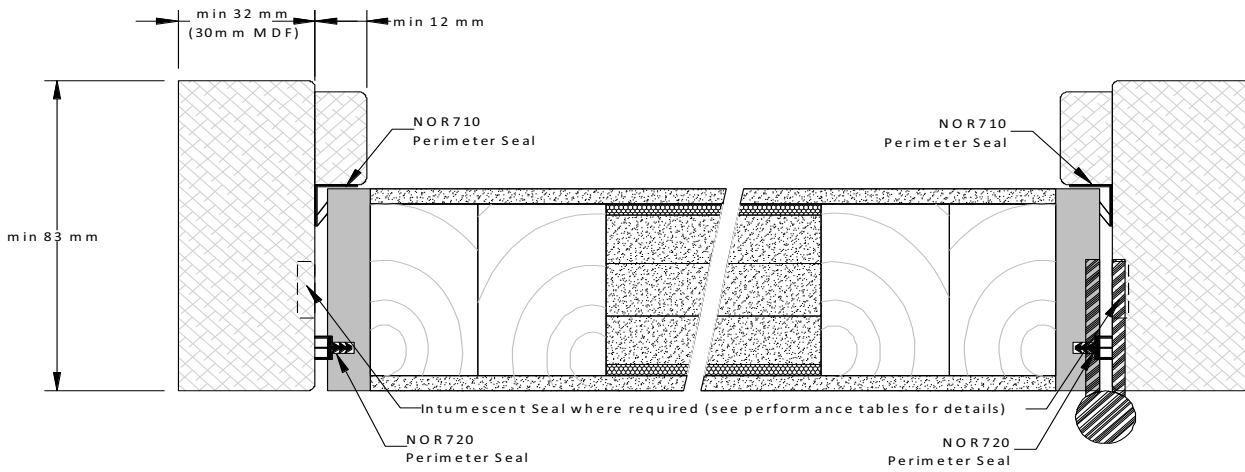

# Tri-Sound DB+ Series 3

## ACOUSTIC/FIRE DOOR CORES

### SECTION 3- FRAME & SEAL CONFIGURATIONS



#### Single Leaf – Seal Set D

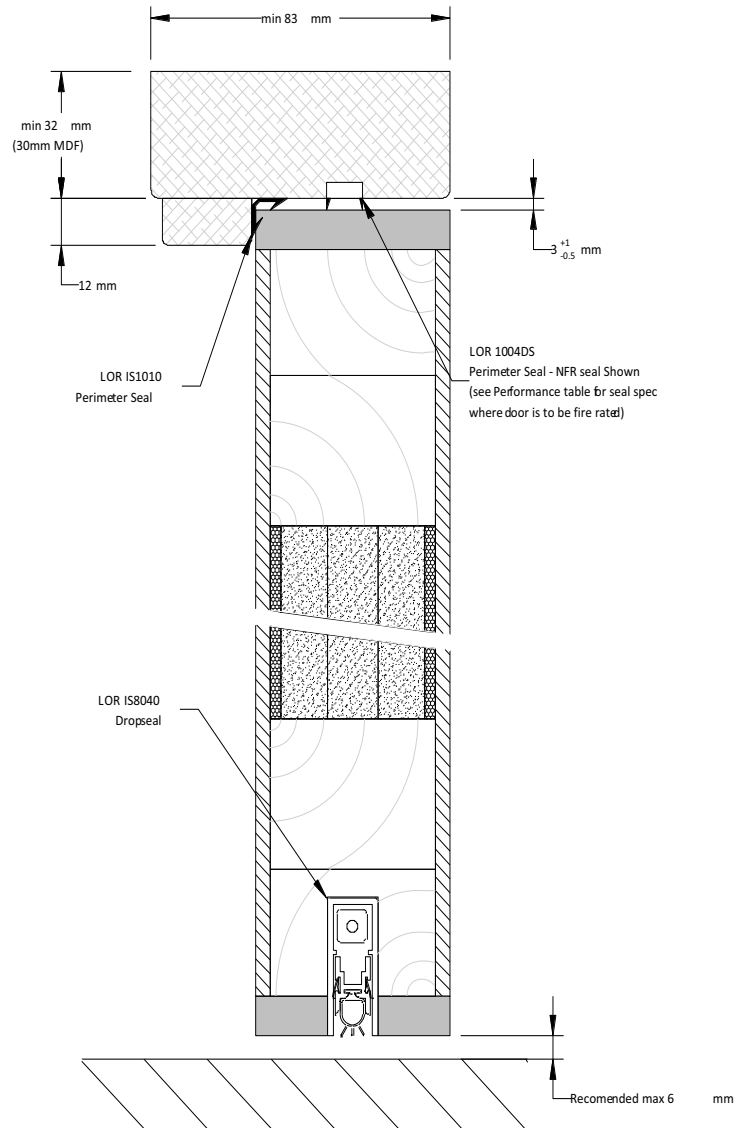
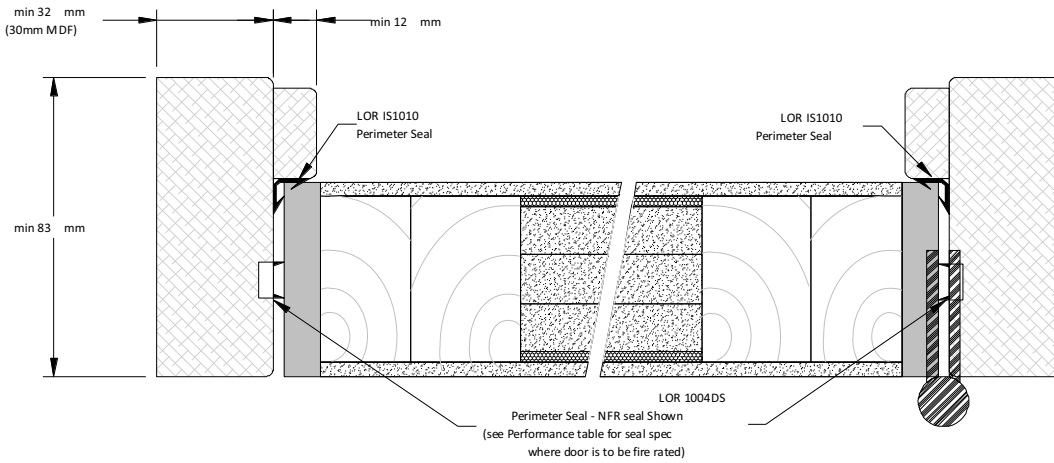

# Tri-Sound DB+ Series 3

## ACOUSTIC/FIRE DOOR CORES

### SECTION 3- FRAME & SEAL CONFIGURATIONS



#### Single Leaf – Seal Set E

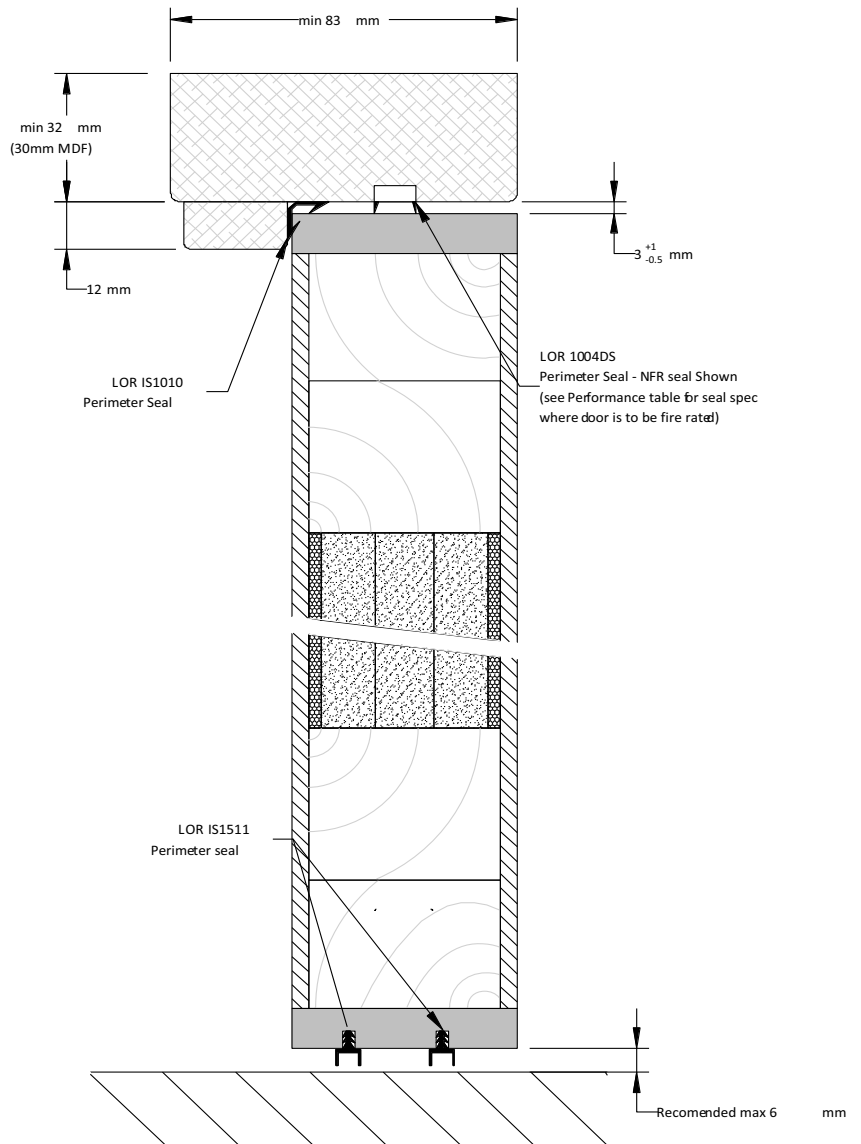
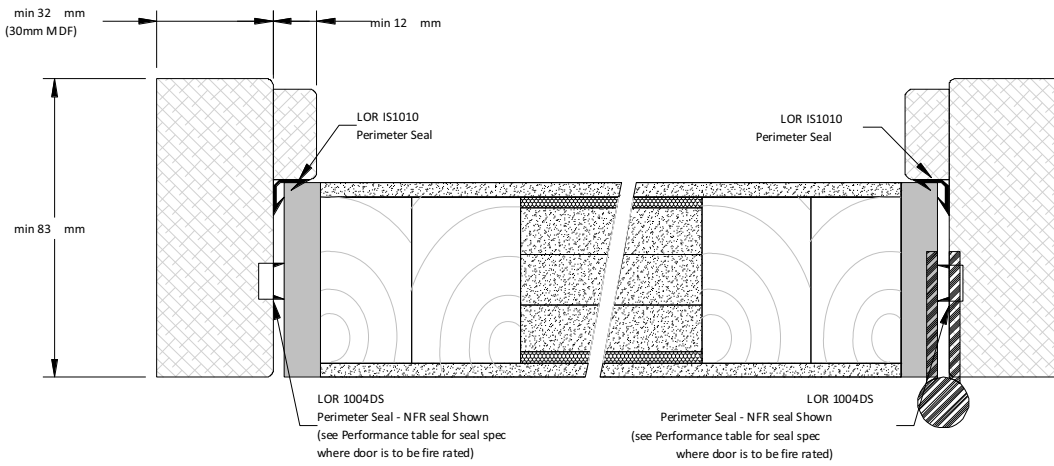



# Tri-Sound DB+ Series 3

## ACOUSTIC/FIRE DOOR CORES

### SECTION 3- FRAME & SEAL CONFIGURATIONS



#### Double Leaf – Seal Set C

